

**RG, RGK, KI  
Operating Instructions  
and RS**



**... made by**

## 1. Linear Drives

(Types RS)

With Linear Drives of these types the pitch and the direction of travel are pre-set and fixed. To change the speed or direction of stroke, the speed and direction of rotation of the shaft must be varied.

## 2. Rolling Ring Drives

(Types RG, RGK and KI)

With Rolling Ring Drives those significant advantages which relate to their operation on a plain shaft are exploited and the pitch and direction of travel can be varied. As a result, reciprocating backwards and forwards motion at a variable speed is possible on a shaft which has a constant speed and direction of rotation.

## 3. Shaft Material

Uhing Linear Drives® require inductive surface hardened ground steel shafts.

Minimum requirements are:

- surface hardness: 50 HRC
- tolerance on diameter: h6
- out of roundness: maximum on half of the diameter variation permitted by ISO h6 tolerance
- concentricity tolerance (DIN ISO 1101)  $\leq 0.1$  mm/m

## 4. Instructions for Fitting

The shaft must be chamfered on its leading edge.

Screw the shaft with applied axial pressure and the correct direction of rotation into the Linear Drive from the end opposite to the pressure screw.

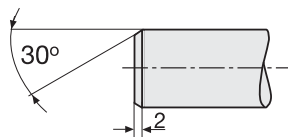

Before screwing in the shaft, first select the maximum pitch setting on the Rolling Ring Unit.

**When attaching any associated equipment to the drive, it is important to ensure that the fixing screws do not penetrate into the housing as this may lead to failure in operation.**

Associated equipment should be mounted as close as possible to the Linear Drive. Significant leverage influences the side thrust output! Secure the Linear Drive against rotation with the shaft. If the unit is secured against rotation

by being coupled with an associated assembly which has its own carriage, care should be taken to ensure alignment compensation at all times through the coupling arrangement.

**The movement of the drive can create nip points. These, and rotating shaft, should be suitably guarded.**

Adjusting screws are identified with red sealant. If the screws are moved, the characteristics of the drive will change. Please refer to paras. 8 and 9. Unauthorized interference with the equipment during the Guarantee Period will invalidate the guarantee.

## 5. Direction of Shaft Rotation

*Linear Drive Nuts*

Linear Drive Nuts are not shaft direction dependent.

*Rolling Ring Drives*

With Rolling Ring Drives the reversal mechanism only operates when the shaft is driven in the correct direction (as specified at the time of ordering).

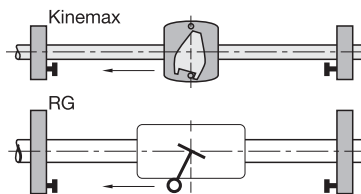

Simple check:

When the shaft is rotated, the roller at the end of the reversal mechanism release lever should be pointing in the direction of travel of the drive.

If this is not the case, either the direction of rotation of the shaft must be changed or the reversal mechanism must be altered as shown in the sketch below:

Screw the shaft into the unit. Remove the reversal lever, springs, release lever and stop bridge.

Turn the release lever through 180° (see sketch) and fit the stop bridge accordingly.

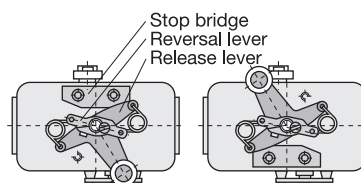

Refit the springs and reversal lever in their previous positions. Check for ease of operation.

RGK

For changing the direction replace the positions of endstops.

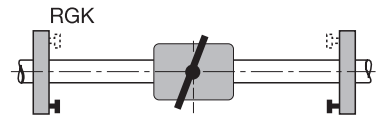

Kinemax KI

With the Kinemax, a reversal of the direction of shaft rotation is only possible in the Uhing works except KI-5. Change of the shaft rotation of a KI3-15-5MCR:

1. Release the screw and remove the reversal lever and the spring.
2. Release the 4 screws at the top plate and remove it too. Take out the outer rolling rings and change the positions of their retainers by turning them 180°.
3. Replace the outer rolling rings.
4. Turn the top plate 180° and fix it with the screws.
5. Replace the spring and reversal lever (turned 180°) and fix the screws.

**Finally check all operational functions. If necessary adjust the symmetry (see para. 11).**

## 6. Adjustment of Pitch and Pitch Direction

*Linear Drives Nuts*

The pitch of Linear Drives Nuts of design category 4 (e.g. RS 4-25-4) is set using a system of wedges and these can be changed to change the pitch. Wedges can be obtained from Joachim Uhing KG GmbH & Co. If a change in pitch direction is required, the wedges must be removed and turned through 180° before being reassembled (the lead edge fitting into the guide slot opposite).

*Rolling Ring Drives*

are, by their nature, variable pitch drives. The pitch is set as follows:  
**Rolling Ring Drives Type C:** via serrated pitch selection scale (before adjusting pitch press tooth on end of pitch selection lever backwards out of serration!)  
**Rolling Ring Drives Type S** have set screws for the setting of the pitch in each direction of travel.  
**Rolling Ring Drives Type Z** via worm driven pitch control (suitable for remote control).

**Kinemax and RGK**

Via self retaining knurled pitch selection knob giving infinitely variable pitch.

The reversal of the direction is, with most models, effected entirely mechanically by driving the release lever section of the reversal mechanism up against a fixed position endstop. Elektromagnetic or pneumatic reversal systems are further available.

**7. Free-Movement Lever**

Uhing Linear Drives® can be fitted with a Free-Movement Lever upon request. It is standard with RG15-2 to RG40-2 and RGK. This serves to release the pressure between the Rolling Rings and the shaft. By turning the lever through 90°, the drive is free to be pushed along the shaft.

**Care should be taken with vertical arrangements! Ensure that the load will not crash on operation of the lever! Danger of injury!**

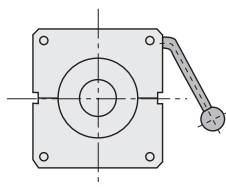

**Important:**

The principle of the Linear Drive is such that, when the Free-Movement Lever is operated, the unit tilts slightly over its length. If a connection is made between the unit and a separately supported guide, care must be taken to ensure that this tilt action is not interfered with.

**8. Slip**

If the Linear Drive is correctly selected and fitted, it should be virtually wear free in operation i.e. slip does not occur.

If, as a result of a fault (e.g. a blockage, an overload or an incorrect direction of rotation of the shaft etc.) the unit slips on a rotating shaft, the shaft must be stopped immediately so as to avoid damage.

**9. Side Thrust**

The side thrust is set in the manufacturer's works at a value which ensures optimum performance and long life. It should not be adjusted by the user.

If, however, problems occur after an extended period of time which

suggest a loss of thrust, corrective action can be taken. To this end, please request from us detailed information concerning the particular drive in question (giving us the exact type reference).

**10. Maintenance**

For the lubrication of the shaft, normally commercially available MoS<sub>2</sub>-free bearing greases can be used, e.g. SKF Alfabub LGMT2, Shell Alvania R2 or G2, Esso Beacon 2.

Procedure:

Clean the shaft and spread the grease as thinly as possible with a rag.

Lubricate the reversal mechanism, particularly the springs, with a viscous machine oil (SAE 90).

Frequency: monthly.

Where the operating conditions are particularly demanding, e.g. where a unit is required to be stationary on a rotating shaft or where it operates under extremely dirty conditions or at temperatures in excess of 80°C, we recommend shorter intervals.

**11. Adjustment of Symmetry for Rolling Ring Drive Units**

If, after a long period of use, there is an unacceptable difference in the pitch in the two directions of travel in the unloaded condition, an adjustment can be made.

**11.1 Models with Serrated Pitch Selection Scale**

(except Type RG 15)

The following tools are necessary:

- A. Circlip pliers
- B. Allen key
- C. Cylindrical pin
- D. Depth gauge

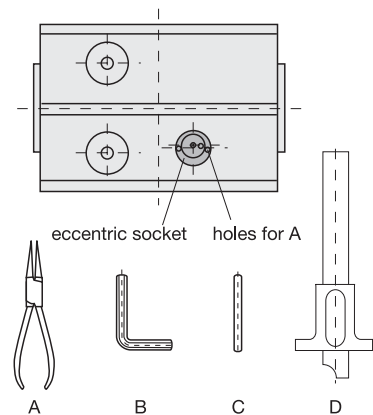

1. Note the starting position of drive (measured from one of the end brackets).

- 2. Select the pitch on scale setting 2 on the serrated pitch selection scale (6) via the pitch setting lever (7).
- 3. Turn the shaft through exactly 5 rotations in the ordered direction of rotation.
- 4. Reverse by manually operating the release lever (2).

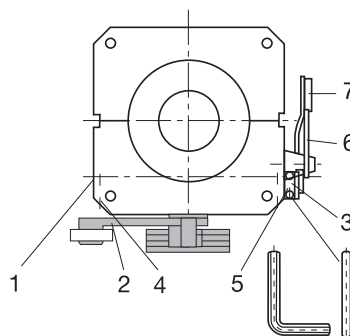

- 5. Continue to rotate the shaft in the **same** direction until the drive has returned to **exactly** its starting point.
- 6. Determine the difference in number of shaft rotations for the forwards and backwards travel.
- 7. If this difference is greater than 1/8 of one rotation of the shaft, slacken the threaded locking pin (4) with an allen key and adjust the eccentric socket (1) with circlip pliers until the difference, when measured again, is within the permitted tolerance of 1/8 of one turn.
- 8. Next, set the pitch selection lever (7) on pitch scale setting 8 and repeat the operations described under paras. 3-6.
- 9. If the difference is greater than 1/8 of one shaft rotation, slacken the threaded locking pin (5) with an allen key and adjust the screw socket (3) with a cylindrical pin to the required setting. Tighten the locking pin prior to making each measurement.
- 10. Each adjustment is checked again by rotating the shaft through five rotations until the results lie within the permissible tolerances.
- 11. Re-check the pitch on the 2 setting and finally check that both of the threaded locking pins (4 and 5) are tightened securely.





**RG 15**

Only one special eccentric socket is used for the setting of pitch symmetry, this being located in the back of the unit. After slacking the two cylinder head slot-head screws, the socket can be rotated and symmetry adjustment in the pitch scale setting 2 is made as described above. After the adjustment has been made, retighten the cylinder head slot-head screws.

Adjustment in the 8 position is made by screwing in or screwing out the threaded pin located in

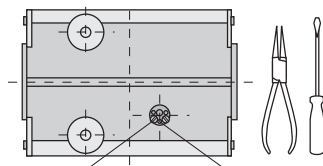

Cylinder head slot-head screw Threaded pin

the eccentric socket. Finally secure the threaded pin with a soluble sealant (e.g. Loctite).

**11.2 Set Screw Type**

Rolling Ring Drives with pitch setting screws can be adjusted by slackening off the lock nut and turning the setting screw related

to the appropriate direction of travel.

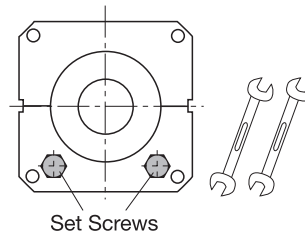

**11.3 Kinemax / RGK**

Both units are adjusted by turning the shaft on which the pitch setting knob is mounted.

First, release the clamp screw seated in the shaft with an allen key and set the pitch selection

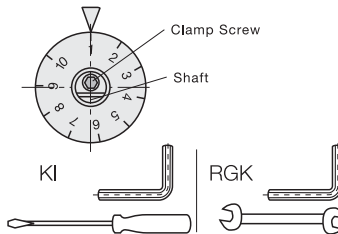

knob on the setting most often used. Check the differences in distance travelled as described

above and turn the shaft with a screwdriver to correct. Finally, retighten the clamp screw after first securing the shaft against rotation.

**12. Replacing Reversal Springs**

To avoid bending (and so altering) the springs when fitting, the reversal lever should be removed. Lubricate springs with Molycote Grease before fitting.

Spring arrangement (Type RG): The longer leg must be inserted into the release lever (with end stop contact roll).

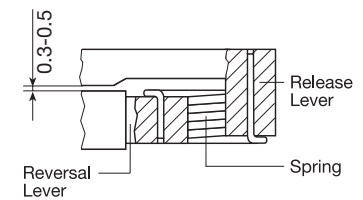

**An air gap of 0,3 - 0,5 mm between release lever and reversal lever has to be ensured during mounting of the reversal lever while the shaft is inserted.** (only for RG types)

**UHING**  
 worldwide service

**The addresses of our agencies are available in the internet:**

**www.uhing.com**



Joachim Uhing KG  
 GmbH & Co.  
 Kieler Straße 23  
 24247 Mielkendorf  
 Tel. +49 (0) 4347 - 906-0  
 Fax +49 (0) 4347 - 906-40  
 e-mail: sales@uhing.com  
 www.uhing.com  
 Germany

